

# Dynapac CC1000 Plus

## Double drum vibratory rollers



### Technical data



#### Masses

Max. operating mass	1750 kg
Operating mass (incl. ROPS)	1685 kg
Module mass (front/rear)	790 kg/895 kg



#### Compaction

Centrifugal force	17 kN
Nominal amplitude	0.4 mm
Static linear load (front/rear)	7.9/8.9 kg/cm
Vibration frequency	70 Hz
Water tank	190 l



#### Traction

Speed range	0-9 km/h
Vertical oscillation	±13°



#### Engine

Manufacturer/Model	Kubota D1105-E4B T4f/V
Type	Water cooled diesel
Rated power, SAE J1995	18 kW (24 hp ) @ 2800 rpm
Fuel tank capacity	23 l



#### Hydraulic system

Driving	Axial piston pump with variable displacement and servo. 2 radial piston motors with constant displacement.
Vibration	Gear pump/motors with constant displacement.
Steering	Gear pump with constant displacem.
Service brake	Hydrostatic in forward and reverse lever.
Parking/ Emergency brake	Failsafe brake in both drums.

Find us locally at [www.dynapac.com](http://www.dynapac.com)

We reserve the right to change specifications without notice. Photos and illustrations do not always show standard versions of machines. The above information is a general description only, all informations are supplied without liability.

# Dynapac CC1000 Plus

## Double drum vibratory rollers



### Technical data

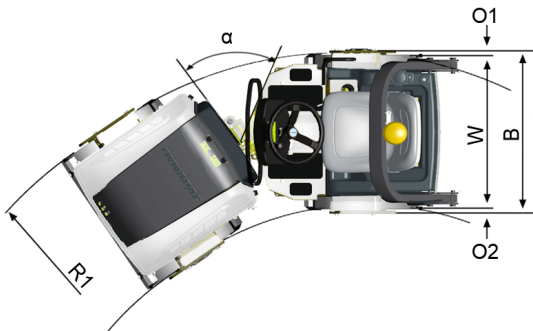
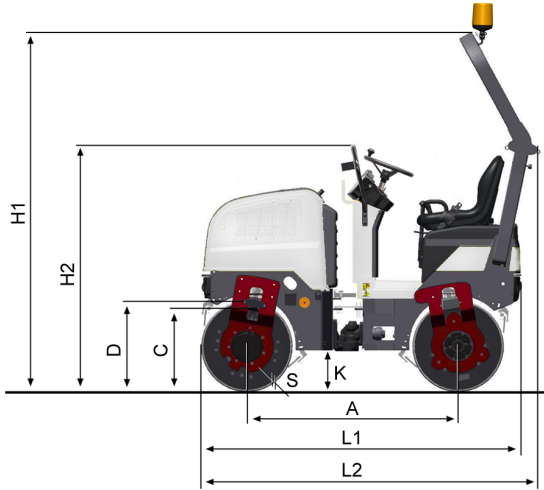

Dimensions	
A. Wheelbase	1350 mm
B. Width	1070 mm
C. Curb clearance	465 mm
D. Drum diameter	584 mm
H2. Height, w/o ROPS/cab	1585 mm
K. Ground clearance	250 mm
L1. Length	2040 mm
L2. Length (ROPS)	2095 mm
O1. Overhang, right	35 mm
O2. Overhang, left	35 mm
R1. Turning radius, outside	2860 mm
S. Drum shell thickness	12 mm
W. Drum width	1000 mm
$\alpha$ . Steering angle	$\pm 34^\circ$

### Optional equipment

#### Air Conditioning /Automatic Climate Control (ACC) (Optional)

- The system contains fluorinated greenhouse gases.
- Coolant designation: HFC-134a
- Coolant weight when full: 1,6 kg
- CO<sub>2</sub>-equivalent: 2288 ton
- GWP: 1430

Find us locally at [www.dynapac.com](http://www.dynapac.com)

We reserve the right to change specifications without notice. Photos and illustrations do not always show standard versions of machines. The above information is a general description only, all informations are supplied without liability.