

# ViO23-6



Type	Zero Tail
Operating Weight	2405 kg
Width1	380 - 1550 mm
Digging Depth2	270 - 2465 mm

Designed for safe working in confined environments, the ViO23-6 is also easy to transport, thanks to its retractable undercarriage and low weight. Advanced hydraulics and indirect-injection engine give it plenty of precision power when it matters. Much is provided for the operator as well, from advanced safety features to comfort-based design in a surprisingly roomy cabin. Quick and easy maintenance can be boosted by SmartAssist Remote, which also offers a wealth of fleet management, productivity and security benefits.



Specifications		ViO23-6
Weight	Transport weight	2170 kg (canopy) / 2330 kg (cabin)
	Operating Weight	2245 kg (canopy) / 2405 kg (cabin)
Engine	Type	3TNV76-PBV1
	Fuel	Diesel
	Net Power	14,3 kW at 2400 rpm
	Gross Power	14,6 kW at 2400 rpm
	Displacement	1.11 l
	Max Torque	62,8 – 68,6 N.m at 1800 rpm
	Starter	12V – 1kW
	Battery	12 V – 36 Ah
	Alternator	12 V – 40 A
	Hydraulic System	Maximum Pressure
Working Pump		2 double piston pump with variable flow / 1 gear pump / 1 gear pump for pilot line
Max Flow		2 x 21,6 l/min / 20,4 l/min / 10,8 l/min
Hydraulic Tank		25 l
Performance	Travel speed	2,2 / 4,2 km/h
	Rotation Speed	10 rpm
	Digging Force (arm)	13,1 / 10,6 kN
	Digging Force (bucket)	17,5 kN
	Traction Force	23,7 / 11,6 kN
	Noise level (2000/14/CE & 2005/88/CE)L	wA: 93 dBA / LpA: 80 dBA
	Fuel Tank	27,5 l



**MAANKATTAVA  
HUOLTOVERKOSTO**



**SUORAAN VARASTOSTA  
VARAOSAT**



**PALVELEVA  
KENTTÄHUOLTO**



**TOIMIVA  
TEKNINEN TUKI**

# Dimensions

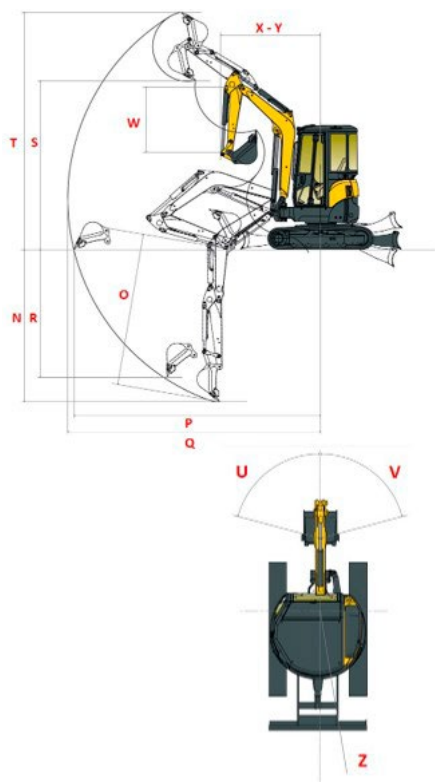
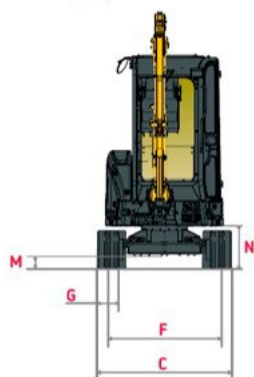
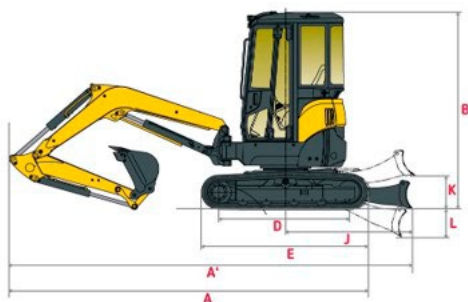

Dimensions		ViO23-6
A	Overall length	3890 / 3910 mm
B	Overall height	2420 / 2480 ** mm
C	Overall width	1380 – 1550 * mm
D	Length of track on ground	1470 mm
E	Undercarriage length	1890 mm
F	Lane	1130 / 1300 * mm
G	Track width	250 mm
H	Overall blade width	1380 / 1550 * mm
I	Overall blade height	290 mm
J	Blade distance	1320 mm
K	Max. blade height above the ground	355 mm
L	Max. lowering blade depth	335 mm
M	Minimum ground clearance	150 mm

Dimensions		ViO23-6
N	Max. digging depth - Blade lifted	2270 / 2465 mm
O	Max. digging depth - Blade lowered	2450 / 2655 mm
P	Max. digging reach on ground	4020 / 4220 mm
Q	Max. digging reach	4140 / 4325 mm
R	Max vertical wall	1870 / 2080 mm
S	Max. dumping height	2570 / 2695 mm
T	Max. cutting height	3840 / 3960 mm
U	Boom swinging base to left	46°
V	Boom swinging base to right	74°
W	Arm length	950 / 1150 mm
X	Minimum front swing radius	1820 / 1850 mm
Y	Minimum front swing radius with boom swing	1530 / 1560 mm
Z	Rear swing radius	690 mm

\* Retracted undercarriage – Extended undercarriage

\*\* Canopy / Cabine



**MAANKATTAVA  
HUOLTOVERKOSTO**



**SUORAAN VARASTOSTA  
VARAOSAT**



**PALVELEVA  
KENTTÄHUOLTO**



**TOIMIVA  
TEKNINEN TUKI**

# Features



## COMPACTNESS

Designed for safe working in confined environments, the ViO23-6 is also easy to transport, thanks to its retractable undercarriage and low weight. Advanced hydraulics and indirect-injection engine give it plenty of precision power when it matters. Much is provided for the operator as well, from advanced safety features to comfort-based design in a surprisingly roomy cabin. Quick and easy maintenance can be boosted by SmartAssist Remote, which also offers a wealth of fleet management, productivity and security benefits.



## VARIABLE UNDERCARRIAGE

The undercarriage retracts to just 1,380 mm, giving it easy access to tight areas. When extended, it measures 1,500 mm. Add in the excellent weight distribution and it's no surprise that the resulting high stability results in impressive digging and loading capabilities. Plus with reduced clearance between the sliding parts, extending the undercarriage does not result in soil build-up. The hinged blade extensions are permanently fixed on the blade, so there's no possibility of losing them. They can also be quickly repositioned without tools.



## VARIABLE UNDERCARRIAGE

The undercarriage retracts to just 1,380 mm, giving it easy access to tight areas. When extended, it measures 1,500 mm. Add in the excellent weight distribution and it's no surprise that the resulting high stability results in impressive digging and loading capabilities. Plus with reduced clearance between the sliding parts, extending the undercarriage does not result in soil build-up. The hinged blade extensions are permanently fixed on the blade, so there's no possibility of losing them. They can also be quickly repositioned without tools.



MAANKATTAVA  
HUOLTOVERKOSTO



SUORAAN VARASTOSTA  
VARAOSAT



PALVELEVA  
KENTTÄHUOLTO



TOIMIVA  
TEKNINEN TUKI

# Features



## HIGH PERFORMANCE

Exceptional productivity is a given, thanks to an advanced combination of excavation power, arm length and extended operating cycles. The robust and reliable Yanmar 3TNV engine features an indirect injection system with mechanical speed governor. The auto-deceleration system and eco-mode setting offer additional fuel reduction possibilities, and there are excellent exhaust emission performances as well. For the hydraulic system, we use a control valve based on the ViPPS principle. This cumulates the flow of separate pumps in order to deliver optimal speed, power, smoothness and balance.



## EXTRA COMFORT

A lot of thought has gone into making life as easy and comfortable as possible for the operator. The machine offers an ergonomic environment, with 360° visibility and exceptional safety features, with both ROPS and FOPS certification. Control levers are sensitive and precise, as well as easily accessible. There's plenty of leg room, together with a flat floor. The exceptionally quiet engine makes working more pleasant as well. An ergonomic suspension seat is available as an optional extra, complete with adjustable controls, high backrest and retractable seat belt.



## EASY MAINTENANCE

The VIO23-6 is designed for optimum long-term reliability, durability and performance in demanding conditions and work environments, with minimal maintenance. All main components are accessible via the easy-to-open bonnet or the right-side cover, which is mounted on one hinge for quick access. A flat floor mat makes cleaning, checking and servicing easier as well. To help reduce downtime, the Yanmar digital interface informs the operator in real time about the machine's status, highlighting when components need attention and providing service assistance. Highly resistant steel panels and full cylinder protection also reduce downtime and total cost of ownership.

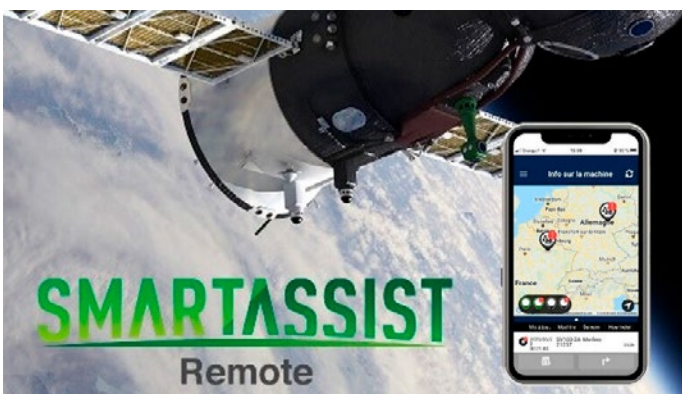

## SMARTASSIST REMOTE

SmartAssist Remote is our unique fleet management system that uses the latest telematic technology to provide optimal visibility on equipment location and status. This compact piece of equipment, available on VIO23-6, will help maximise work potential. By providing real-time information, it gives you total control and lets you monitor and manage your machines remotely via a PC or smartphone. You can check location, energy efficiency, consumption and maintenance requirements at any time. You can also opt for alerts in case of malfunction or unusual activity - making it a useful security tool.



MAANKATTAVA  
HUOLTOVERKOSTO



SUORAAN VARASTOSTA  
VARAOSAT



PALVELEVA  
KENTTÄHUOLTO



TOIMIVA  
TEKNINEN TUKI