

ViO50-6B



Type	Zero Tail
Operating Weight	3695 kg
Width	1740 mm
Digging Depth	3350 mm

Specifications		ViO38-6
Weight	Transport weight	3500 kg (canopy) / 3620 kg (cabin)
	Operating Weight	3575 kg (canopy) / 3695 kg (cabin)
Engine	Type	3TNV88-ESBV
	Fuel	Diesel
	Net Power	18.5 kW / 24.8 HP at 2200 rpm
	Gross Power	18.9 kW / 25.3 HP at 2200 rpm
	Displacement	1.642 l
	Max Torque	85.5 – 94.5 N.m
	Starter	12 V - 1.7 kW
	Battery	12 V – 65 Ah
	Alternator	12 V – 55 A
	Hydraulic System	Maximum Pressure
Working Pump		2 double piston pump with variable flow / 1 gear pump / 1 gear pump for pilot line
Max Flow		2 x 37 l/min / 26.2 l/min / 10.8 l/min
Hydraulic Tank		40 l
Performance	Travel speed	2.7 / 4.5 km/h
	Rotation Speed	9.5 rpm
	Digging Force (arm)	18.1 kN
	Digging Force (bucket)	32.1 kN
	Traction Force	n/a
	Noise level (2000/14/CE & 2005/88/CE)	Lwag: 94 dBA ; Lpag: 82 dBA
	Fuel Tank	41 l



**MAANKATTAVA
HUOLTOVERKOSTO**



**SUORAAN VARASTOSTA
VARAOSAT**



**PALVELEVA
KENTTÄHUOLTO**



**TOIMIVA
TEKNINEN TUKI**

Dimensions

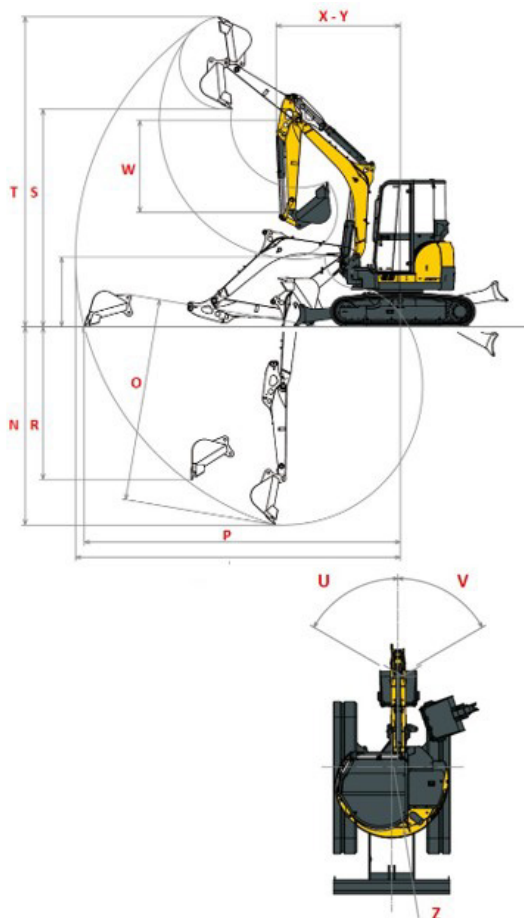
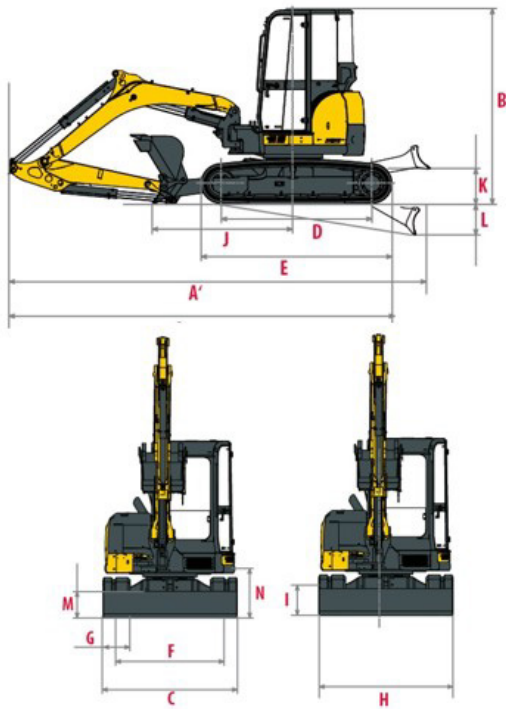

Dimensions		ViO50-6B
A	Overall length	5230 / 5330 * mm
B	Overall height	2540 mm
C	Overall width	1940 mm
D	Length of track on ground	2070 mm
E	Undercarriage length	2590 mm
F	Lane	1590 mm
G	Track width	350 mm
H	Overall blade width	1970 mm
I	Overall blade height	400 mm
J	Blade distance	1890 mm
K	Max. blade height above the ground	500 mm
L	Max. lowering blade depth	540 mm
M	Minimum ground clearance	345 mm

Dimensions		ViO50-6B
N	Max. digging depth - Blade lifted	3360 / 3610 * mm
O	Max. digging depth - Blade lowered	3540 / 3790 * mm
P	Max. digging reach on ground	5540 / 5770 * mm
Q	Max. digging reach	5700 / 5920 * mm
R	Max vertical wall	2690 / 2880 * mm
S	Max. dumping height	3870 / 4000 * mm
T	Max. cutting height	5530 / 5650 * mm
U	Boom swinging base to left	68°
V	Boom swinging base to right	68°
W	Arm length	1450 / 1700 * mm
X	Minimum front swing radius	2190 / 2360 * mm
Y	Minimum front swing radius with boom swing	1760 / 1910 mm
Z	Rear swing radius	970 mm

* With long arm



**MAANKATTAVA
HUOLTOVERKOSTO**



**SUORAAN VARASTOSTA
VARAOSAT**



**PALVELEVA
KENTTÄHUOLTO**



**TOIMIVA
TEKNINEN TUKI**