

ViO17



Type	Zero Tail
Operating Weight	1765 kg
Width	950 - 1280 mm
Digging Depth	2200 mm

The most compact machine you'll find of its kind, the ViO17 can also be both the narrowest and widest, thanks to its variable undercarriage. This means it's also the most stable. It also leads the field in other important areas, thanks to its monoblock chassis for robustness, and three pumps which allow it to generate the most power of any comparable machine. Exceptionally durable, the ViO17 is also surprisingly easy to maintain.



CIVIL ENGINEERING



AGRICULTURE



CONSTRUCTION



LANDSCAPING

Specifications		ViO17
Weight	Transport weight	1690 kg
	Operating Weight	1765 kg
Engine	Type	3TNV70-XBV
	Fuel	Diesel
	Net Power	10,1 at 2200 rpm
	Gross Power	10,3 at 2200 rpm
	Displacement	0.854 l
	Max Torque	47,8 - 52 N.m / 1600 rpm
	Starter	12 V - 1.4 kW
	Battery	12 V – 45 Ah
	Alternator	12 V – 20 A
	Hydraulic System	Maximum Pressure
Working Pump		1 double piston pump with variable flow / 1 piston pump with variable flow / 1 gear pump for pilot line
Max Flow		2 x 17,6 l/min / 13,2 l/min / 11,2 l/min
Hydraulic Tank		16,5 l
Performance	Travel speed	2,1 – 4,3 km/h
	Rotation Speed	9,5 rpm
	Digging Force (arm)	8,5 kN
	Digging Force (bucket)	15,2 kN
	Traction Force	n/a
	Noise level (2000/14/CE & 2005/88/CE)	93 dBA / 81 dBA
	Fuel Tank	20 l



MAANKATTAVA
HUOLTOVERKOSTO



SUORAAN VARASTOSTA
VARAOSAT



PALVELEVA
KENTTÄHUOLTO



TOIMIVA
TEKNINEN TUKI

Dimensions

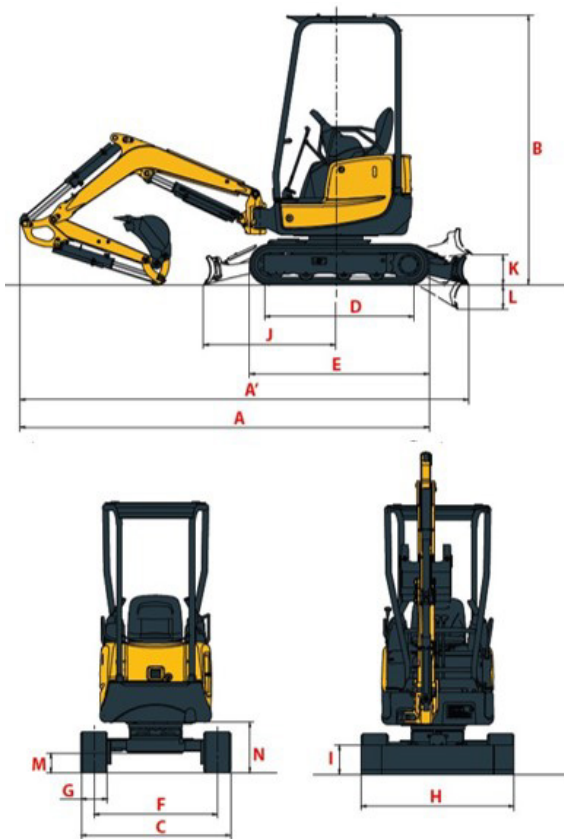

Dimensions		Vi017
A	Overall length	3450 mm
B	Overall height	2370 mm
C	Overall width	950 - 1280 * mm
D	Length of track on ground	1175 mm
E	Undercarriage length	1525 mm
F	Lane	720 - 1050 * mm
G	Track width	230 mm
H	Overall blade width	950 - 1280 * mm
I	Overall blade height	255 mm
J	Blade distance	1120 mm
K	Max. blade height above the ground	265 mm
L	Max. lowering blade depth	205 mm
M	Minimum ground clearance	175 mm

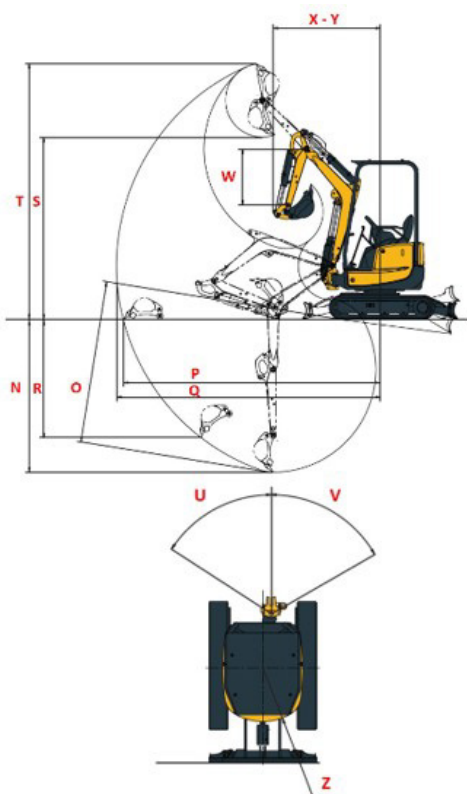

Dimensions		Vi017
N	Max. digging depth - Blade lifted	2200 mm
O	Max. digging depth - Blade lowered	2310 mm
P	Max. digging reach on ground	3710 mm
Q	Max. digging reach	3810 mm
R	Max vertical wall	1850 mm
S	Max. dumping height	2630 mm
T	Max. cutting height	3690 mm
U	Boom swinging base to left	45°
V	Boom swinging base to right	75°
W	Arm length	950 mm
X	Minimum front swing radius	1535 mm
Y	Minimum front swing radius with boom swing	1320 mm
Z	Rear swing radius	640 mm

* Retracted – Extended Undercarriage



**MAANKATTAVA
HUOLTOVERKOSTO**



**SUORAAN VARASTOSTA
VARAOSAT**



**PALVELEVA
KENTTÄHUOLTO**



**TOIMIVA
TEKNINEN TUKI**

Features



COMPACTNESS

The ViO17 is the most compact machine in its class, and with its zero tail swing it's the ideal choice for working in tight conditions. The machine's upper frame can slew within its track width, enabling the operator to concentrate on the task in hand without worrying about damage. Easy to transport, the ViO17 is intended for a wide range of applications, including urban renewal, grading and landscaping.



UNIQUE UNDERCARRIAGE

The ViO17 is fitted as standard with a variable undercarriage which can be easily extended or retracted by operating a simple lever. It means it can go from the narrowest of its kind to the widest - factor in its extremely low centre of gravity and it's not surprising that it also offers the best stability in its class. In addition, the one-piece monoblock chassis provides extra robustness and acts as a counterweight, distributing weight over 360 degrees all around the machine.



POWERLINE

High-capacity hydraulic oil, the cooling system, and other components are all designed for maximum efficiency, ensuring no overheating or loss of hydraulic performance, even in hot conditions. Powerful yet quiet, the engine offers excellent fuel economy. ViPPS hydraulics deliver controllability and power, while thanks to its three pumps (two variable flow and one gear pump), the ViO17 generates more power than any machine of its size. Even the bucket breakout force is top level.



MAANKATTAVA
HUOLTOVERKOSTO



SUORAAN VARASTOSTA
VARAOSAT



PALVELEVA
KENTTÄHUOLTO



TOIMIVA
TEKNINEN TUKI

Features



HIGH PERFORMANCE

The ViO17 is very well balanced, with higher lifting capacities and unloading height than you might expect in such a compact frame. There's a large front lifting capacity with raised blade, plus a lifting cylinder under the arm to ensure a higher lifting force. This cylinder, like all parts of the arm, is completely protected. The higher position of the blade allows easy travel operation in difficult ground conditions and makes it easier to stay level on sloping ground, while trench digging involves no footprint.



DURABILITY

Durability is a key feature throughout, with even the hoses protected with abrasion-resistant sleeves. The structure of the chassis and durable steel covers provide fool-proof resistance. In addition, the large counterweight protects against possible shocks and friction against the walls. The ViO17 also benefits from unique and complete protection of all its boom and arm cylinders. Cylinder tubes and rods are all safeguarded by a spring type steel plate, which significantly reduces the total cost of ownership of the machine.

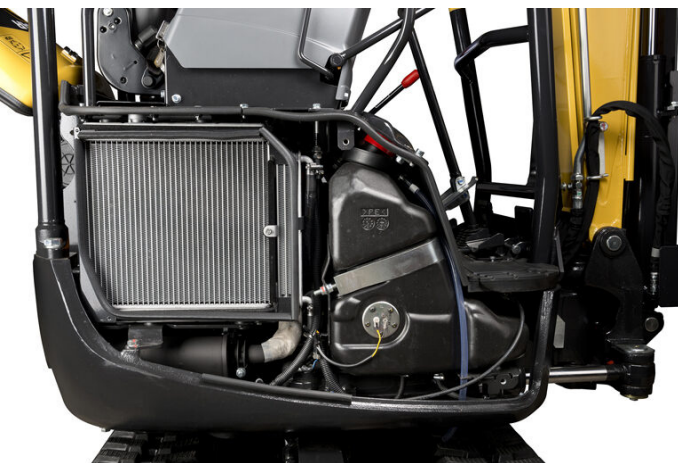

EASY MAINTENANCE

To lower maintenance time and costs, the rear and side covers, the panel under the seat and the removable floor all provide direct access to service points. This means that the fuel tank, radiator, battery, generator, hydraulic equipment and return filter and more are all quickly reachable. Even the distributor under the platform is easily accessible. In addition, the blade cylinder flexible is made of two parts for quick replacement in case of perforation. The rear-opening bonnet allows for easy daily inspection of the engine.



MAANKATTAVA
HUOLTOVERKOSTO



SUORAAN VARASTOSTA
VARAOSAT



PALVELEVA
KENTTÄHUOLTO



TOIMIVA
TEKNINEN TUKI